

# PFiX Controls®

(205) 533-0571  
www.pfixcontrols.com

## Model 4288 Process Controller

---

### Standard Features

**Power Supply:**  
+24VDC @ 2 – 4 Amps  
Depending on load of  
external I/O devices

**Analog Outputs:**  
4mA – 20mA @ +24VDC

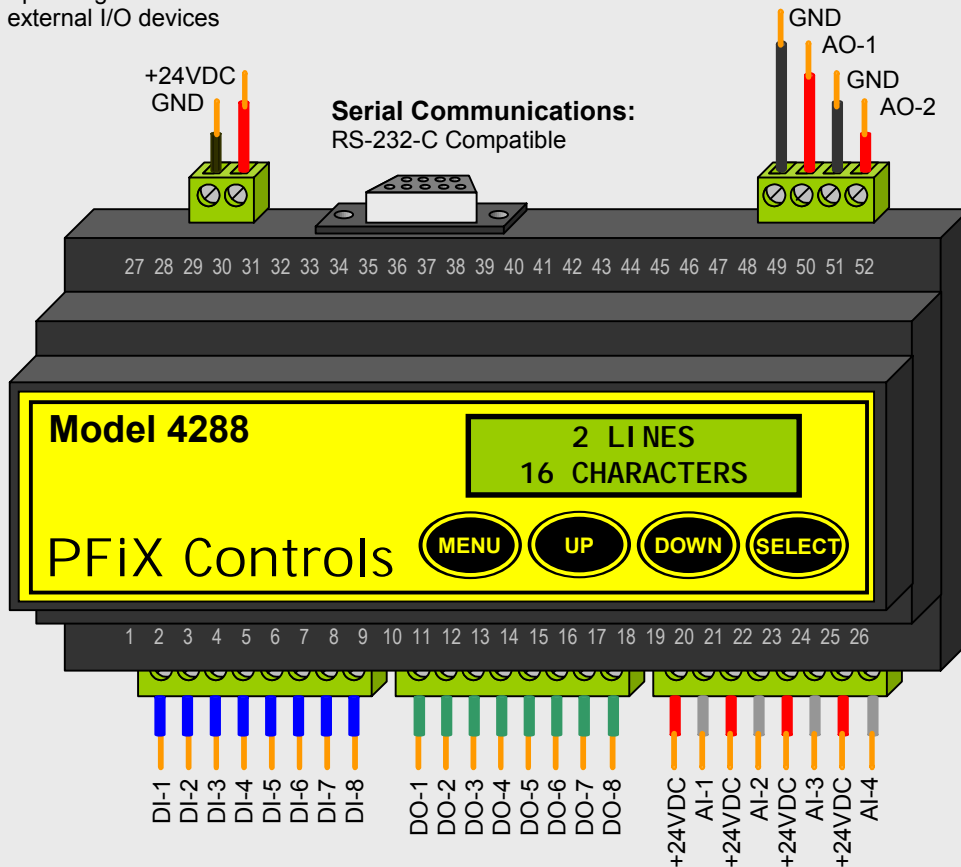

**Digital Inputs:**  
Activate by switching to GND  
Internal pull-up to +5VDC

**Digital Outputs:**  
+24VDC @ 250mA  
Switches to GND

**Analog Inputs:**  
4mA – 20mA inputs with  
+24VDC Loop Power

**DIN Rail Mountable**  
6.15" Wide, 3.35" High, 2.28" Deep  
2 Line, 16 Character LCD with back light  
4 Button User Interface